



The town of Provadiya
Tel.: 051844136 Fax: 051846943
Mobile: 0887 496953
Email: impresia@mail.bg
www.impresia.net

TECHNICAL SPECIFICATIONS USER MANUAL FOR INSTALLATION, USE, MAINTENANCE AND CONTROL OF THE EQUIPMENT

Company: IMPRESIA 99 LTD

Swing model A01-6



I. TECHNICAL SPECIFICATIONS

1. General Characteristics

Model	A01-6
Age group	Up to 3 years
Maximum free fall height	38 cm
Types of games	Swinging
Admissible surfaces for the fall area	Grass, sand, wooden chips, shock-absorbing synthetic surface
Standards compliance	BSS EN1176-1, BSS EN1176-6, BSS EN1176-7
Warranty period	24 months

2. Facility overall dimensions and minimum space to deploy

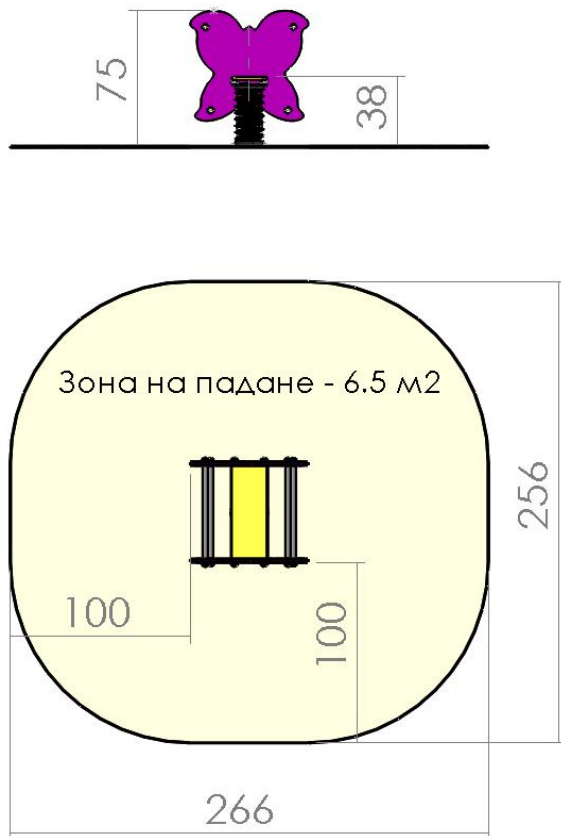

3. Materials Used

1. The body of the rocking swing is made of 6 mm steel base with $\Phi 25$ mm steel pipes welded to it.

The base is attached to the spring with $\Phi 12$ mm U-bracket and M12 nut. The spring is made of special $\Phi 20$ mm steel and its size is 3400 mm / $\Phi 160$ mm. The swing is attached to the ground with steel foundation.

2. Wooden profiled wood modules

Additional softwood modules— a seat, has been used for facility manufacture. It is made of profiled 35 mm thick wood, that is dried up to 10% humidity, impregnated with a primer that protects against decay and is triple varnished with environmentally-friendly acrylic varnishes for outdoor use, meeting the requirements of BSS EN1176-1. All edges are rounded with 3 mm radius.

3. Plywood modules

Volume water-proof 18 mm thick plywood is used for flat module manufacture. Before being varnished these modules undergo surface polyester resin treatment for further moist insulation and increased hard-wearing. After that they are impregnated with a primer that protects against decay and are triple varnished with environmentally-friendly acrylic varnishes for outdoor use, meeting the requirements of BSS EN1176-1.

4. Polyethylene elements

All polyethylene elements (seats, safety caps, plugs) are made by high-quality colour high-density polyethylene injection moulding and by adding the ingredients to ensure necessary plasticity and outdoor weathering and UV light resistance.

5. Rubber elements

All rubber elements of the facility are made of colour SDR styrene-butadiene rubber with shore80 hardness, corresponding to outdoor weathering and UV light resistance requirements.

6. Fits

Individual modules and structure are assembled by means of metal, threaded galvanised lining with M8, M10 and M12. All bolt and nut heads not having flat configuration and for which no special instrument is needed are hidden by means of special caps.

Some modules are fastened to structure by means of galvanised angle straps having the necessary thickness, which ensure module strength indices.

7. Inset parts

Facility is fastened to the terrain by means of galvanised metal inset parts which are connected to facility columns and terrain-connected modules through metals bolts and nuts with cap-insulated heads.

II. FACILITY INSTALLATION

Facility is to be fixed to the existing terrain in compliance with Device Constructive Opinion by means of concrete foundations with the dimensions specified or by being anchored to an existing concrete slab which is not less than 10 cm thick and reinforced in the anchoring area by means of concrete 10/90 anchors, certified with Structure Installation Certificate.

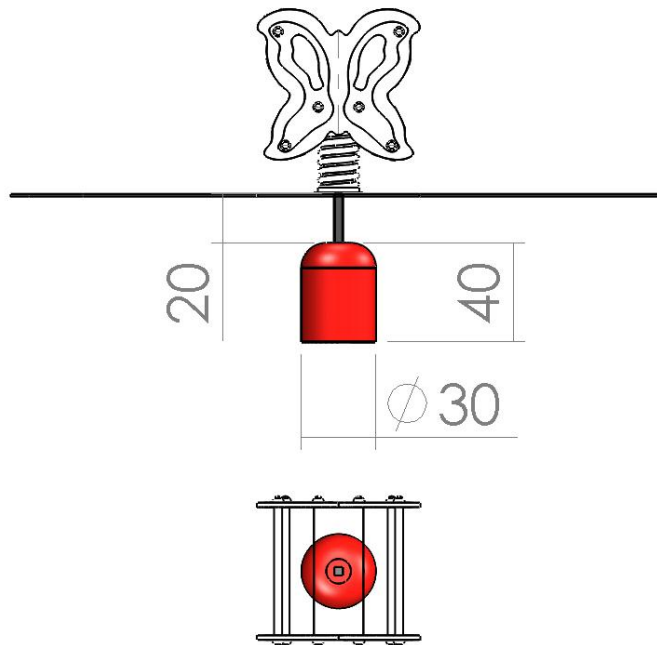

III. GENERAL INSTRUCTIONS FOR FACILITY MAINTENANCE

> In compliance with BSEEN 1176 and Ordinance No. 1 dated January 12th 2009 laying down the rules for Playground Safety and Structure (State Gazette, issue 10/2009), the facility is subject to continuous, periodical and annual primary supervision.

- Continuous supervision is exercised by playground owner once every 7-10 days to establish if there are any visible dangers.

- Periodic supervision is exercised by playground owner once every 1 to 3 months depending on playground visiting frequency. Periodic supervision is exercised for provision of a detailed inspection of play facility functioning and stability as a result of their wear and tear.

- Annual supervision is exercised for provision of a complete and detailed inspection of the general playground safety level in compliance with the requirements specified in the aforementioned Ordinance.

> In case any irregularities are found, measures to eliminate the established dangers and risks related to playground safe exploitation must be taken.

.....
For company: IMPRESIA 99 Ltd