



The town of Provadiya  
Tel.: 051844136 Fax: 051846943  
Mobile: 0887 496953  
Email: impresia@mail.bg  
www.impresia.net

# TECHNICAL SPECIFICATIONS USER MANUAL FOR INSTALLATION, USE, MAINTENANCE AND CONTROL OF THE EQUIPMENT

Company: IMPRESIA 99 LTD

Fitness Facility, model F15

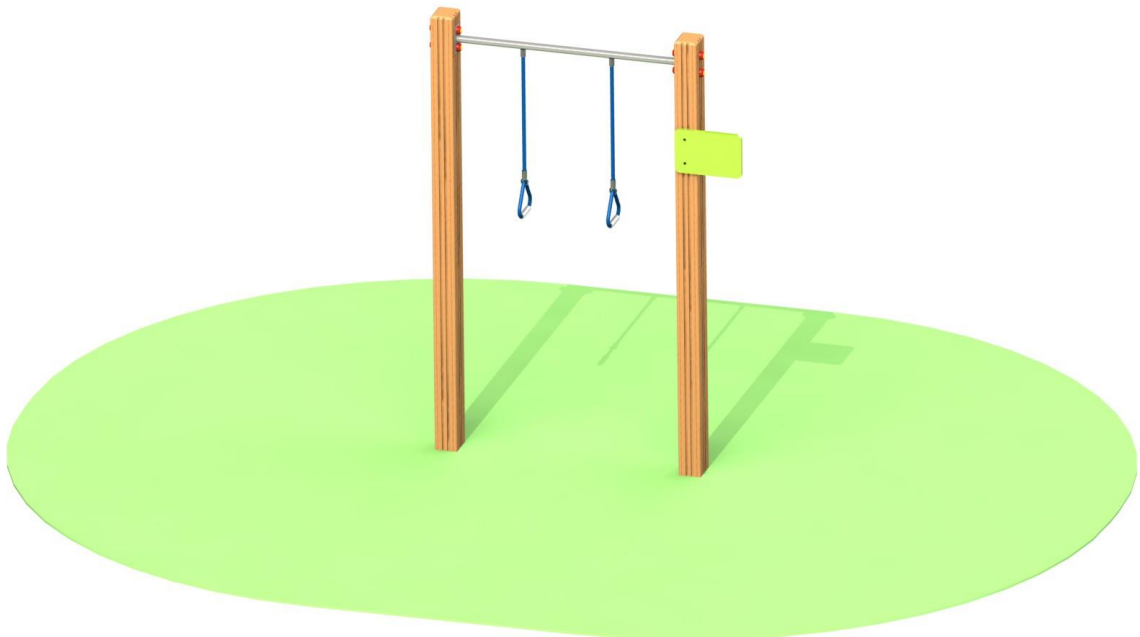

## I. TECHNICAL SPECIFICATIONS

### 1. General Characteristics

Model	<b>F15</b>
Maximum free fall height	98 cm
Types of sports	Hovering exercises rings
Admissible surfaces for the fall area	Grass, sand, wood chips, synthetic shock-absorbing flooring
Standards compliance	<b>BDS EN 16630:2015</b>
Warranty period	24 months

## 2. Dimensions of the Equipment and Minimum Space for Placement

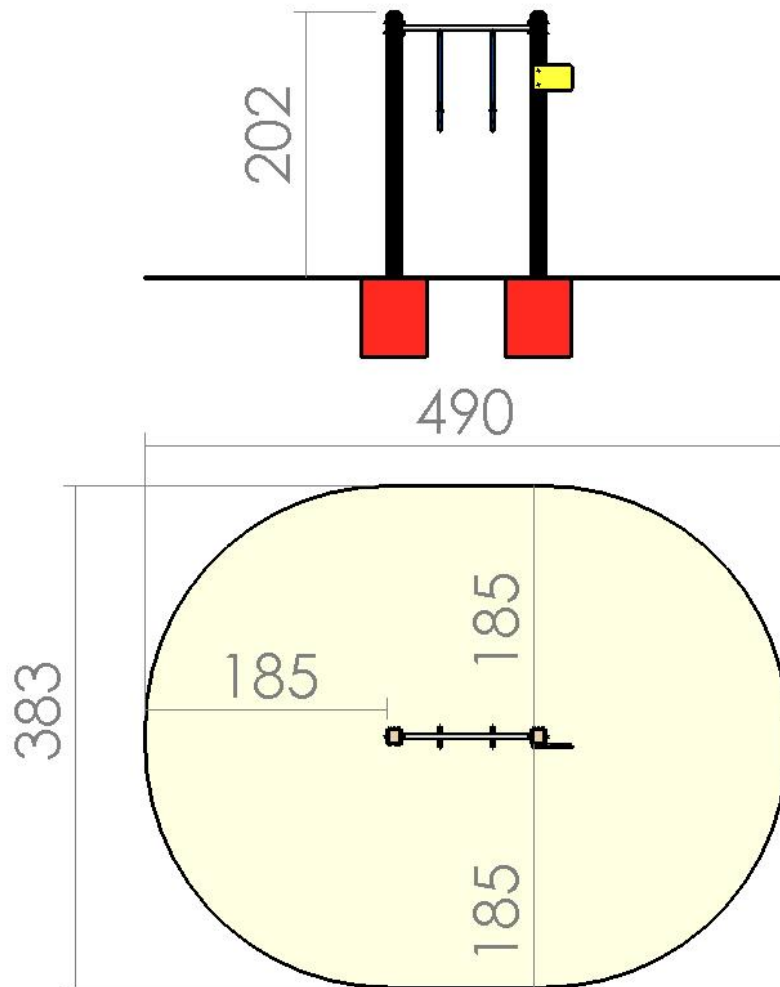

**Зона на падане - 18 м<sup>2</sup>**

## 3. Materials Used

- The structural elements are produced of selected dried double layer softwood with the appropriate profile. Their technical and operational characteristics correspond to the loads required during the operation of the equipment. The equipment structure is designed in accordance with the **BDS EN 16630:2015** requirements both in terms of the fixed and variable loads depending on the number of users in the particular area, and in regards with all requirements of this standard for protection against falls and protection against all types of clamps. The structure is certified by Construction Declaration and in-house Test Reports. All parts are round, with a radius of less than 3 mm, and are polished, impregnated and varnished with three layers of environmentally-friendly acrylic varnish suitable for outdoor conditions (attested by a varnish certificate). The joints are covered by galvanized metal threaded lining with countersunk heads and cannot be disassembled without the use of a special tool. All other metal parts and components of the equipment are protected against weather conditions by non-toxic coatings.
- The sports facilities are made of aluminium pipes with the required size and strength.
- All modules of the equipment, which include cable components, are made of special multi-wire rope with a diameter of 16 mm and suitable polyamide mesh. The rope is attached by

steel plating and aluminium press sleeves (Quality Certificate of the rope and plating issued by the manufacturer).

- The plywood used in the production features maintains the required water resistance and has a three layer acrylic varnish coating with UV protection.

## II. ASSEMBLY OF THE EQUIPMENT

The equipment should be mounted on the ground in accordance with the Construction Declaration of the product through concrete foundations with the required dimensions.

## II. GENERAL INSTRUCTIONS FOR MAINTENANCE OF THE EQUIPMENT

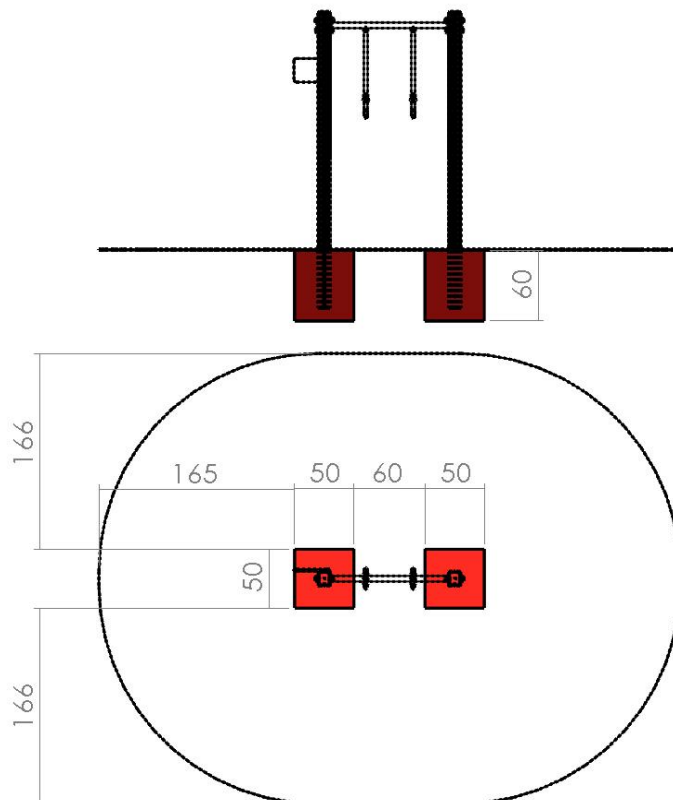

> According to **BDS EN 16630:2015** and Ordinance № 1 of January 12<sup>th</sup>, 2009 on the Terms and Conditions for Playgrounds Structure and Safety (State Gazette, issue 10/2009) the equipment is subject to regular, periodic and annual monitoring.

- The regular monitoring is carried out by the owner of the playground once every 7 - 10 days in order to examine for any obvious dangers.

- The periodic monitoring is carried out by the owner of the playground once every 1 - 3 months depending on how often the playground is visited. The periodic monitoring is carried out for the purpose of detailed examination of the functioning and stability of the play facilities due to their wearing.

- The annual monitoring is carried out for the purpose of complete and detailed examination of the overall level of safety on the playground, which should comply with the requirements of the above-mentioned Ordinance.

> In case of any troubles, measures to eliminate the identified hazards and risks for the safe operation of the playground should be taken.

.....  
For company: IMPRESIA 99 Ltd